

# Design Guide

**Successful projects** begin with a partnership.

## Design Goals

Signicast's goal is to work in partnership with the customer to produce high quality investment cast components that will provide superior performance and durability. This requires sound mechanical design of the final component and the investment casting, reliable process controls, consideration of marketplace economic requirements, and clear communication among all parties.

In any manufacturing process, the price of a product will increase as the dimensional tolerance and inspection criteria become more stringent. At Signicast, we believe that early involvement and input by our technical staff allows our customers to overcome traditional casting tolerance issues. This is accomplished by innovation and technology to provide 100% conformance to specifications as-cast, delivered on time, at the lowest total cost.

The most important guideline to remember is to get Signicast involved early in the design stage.

## ! Size and Weight

Part size and weight are the most critical factors in determining part cost because mold capacity is limited by both size and weight. The more pieces that can run on a mold, the lower the part cost. Unnecessary mass should always be removed by correct engineering practices to reduce part weight.

## ! Number of Gates

When possible, a part should be designed so that a single gate can feed the part. This will generally yield more pieces per mold and reduce the pour weight per mold. Single gate feeding also enhances the dimensional stability of a given part by providing a directional solidification pattern.

## ! Castability

If a design contains features that will raise scrap or rework rates (and piece price), the Signicast Estimating Engineer will recommend design modifications to keep the piece price down.

## Linear Tolerances

The investment casting process is capable of excellent repeatability. As cast process capability of +/- three standard deviations when a single point location is repeatedly measured is typically +/- .003 to +/- .004 per inch. However, tolerance capability is largely influenced by part configuration. Symmetrical shapes with uniform wall sections will solidify with much less variation and distortion than non-symmetrical, non-uniform shapes.

## Normal Linear Tolerances

Normal linear tolerances for normal dimensions reflect these three sources of variation:

**Prediction of Part Shrinkage Factors (20%)**

**Diemaker and Tooling Tolerance (10%)**

**Process Variation (70% of linear tolerance)**

This variation is a combination of part configuration effects that result in non-uniform shrinkage, and all other process variation in producing a wax pattern, ceramic mold, and the casting.

ENGLISH (inches)		METRIC (millimeters)	
Dimension	Tolerance	Dimension	Tolerance
Up to .500"	+/- .007	Up to 15mm	+/- 0.20
Up to 1.000"	+/- .010	Up to 25mm	+/- 0.25
Up to 2.000"	+/- .013	Up to 50mm	+/- 0.35
Up to 3.000"	+/- .016	Up to 75mm	+/- 0.40
Up to 4.000"	+/- .019	Up to 100mm	+/- 0.50
Up to 5.000"	+/- .022	Up to 125mm	+/- 0.55
Up to 6.000"	+/- .025	Up to 150mm	+/- 0.65
Up to 7.000"	+/- .028	Up to 175mm	+/- 0.70
Up to 8.000"	+/- .031	Up to 200mm	+/- 0.80
Up to 9.000"	+/- .034	Up to 225mm	+/- 0.85
Up to 10.000"	+/- .037	Up to 250mm	+/- 0.95
Allow +/- .003" for each additional inch.		Allow +/- 0.1mm for each additional 25mm.	

## Premium Linear Tolerances

All three sources of variation can be reduced by:

1. Part redesign, including addition of tie bars, ribs, and gussets to contain shapes.
2. Tuning of wax injection tooling after the first sample to meet nominal dimensions.
3. Straightening/coining
4. Additional inspection/gaging
5. Machining

All of these can assist in obtaining tighter-than-normal tolerances. There are additional costs associated with items 2 through 5 in this list. Signicast will work with the customer to meet the design requirements in the most economical manner. Premium tolerance capability can be achieved, but must be considered on a part-by-part, dimension-by-dimension basis.

Signicast is capable of holding +/- .002 in some features, although +/- .004 per inch is a more typical premium cast tolerance.

! Premium tolerances may add secondary operations and cost to a part. It is important to designate tight tolerances that are necessary to part function and leave the rest open to normal linear tolerances.

## General Linear Tolerances

What about dimensions that are on a drawing or CAD file simply to describe the shape? These dimensions can be most economically produced by applying a broader General Linear Tolerance.

Another strategy that works well is to incorporate these types of features into a 3-D CAD file for the part but not dimension them for inspection purposes. The feature is then tooled per the design, but valuable inspection and evaluation time is used only for features important to the customer.

ENGLISH (inches)		METRIC (millimeters)	
Dimension	Tolerance	Dimension	Tolerance
Up to 2"	+/- .020	Up to 50mm	+/- 0.50
Each additional 1.000"	+/- .010	Each additional 25mm	+/- 0.25

## Tooling

- Signicast utilizes a system of tooling standards to ensure uniform high quality design and fabrication of wax injection dies which are guaranteed for the life of the part.
- Type of tooling in order of least expensive tooling but highest piece price:
  - Manual** – Prototype or low volume production work.
  - Semi-Automatic** – Parts that are too large or fragile for fully automatic.
  - Fully Automatic** – Higher volume parts that can be ejected into a water bath. It is less labor intensive and increases productivity.
- More cavities means higher tooling cost, but also increases productivity.
- Configurations that do not allow metal cores in tooling to be drawn due to undercuts or complicated internal shapes must be treated in one of the following ways:
  - Collapsible Cores** – Lowest piece price, higher tooling cost.
  - Loose Inserts** – Best for low volume parts, not an option for fully automatic tools.
  - Multi-Piece Wax Assemblies** – Best for certain configurations, tolerance control suffers along with increased part price.
  - Soluble Cores** – Requires additional die for the soluble core and increased labor for injection and removal of the soluble pattern. Provides excellent flexibility at moderate additional cost.
  - Pre-Formed Ceramic Cores** – High cost for specialized shapes. Used instead of soluble pattern because coring would not be properly coated during shell building process.

### Soluble Wax

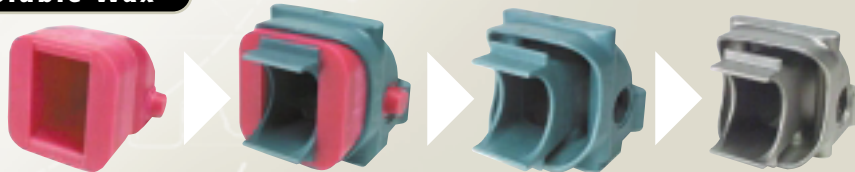

### Ceramic Coring

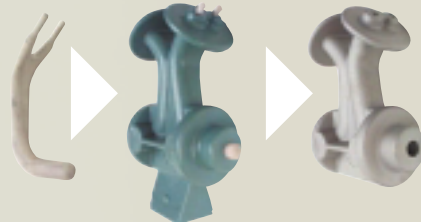

## Flatness and Straightness

Parts will be held flat and/or straight to .005" per inch of length. Heavy part sections may be dished up to an additional .010".

Unless otherwise agreed, feeler gauge and surface plate (or straight edge) methods will be used to inspect flatness and straightness.

- ! Straightening sometimes cannot be avoided and does add to costs. Do not specify tighter flatness, straightness, roundness, etc. requirements than you actually require.
- ! The actual straightening costs are often dependent on the tightness of the tolerance specified.
- ! Signicast generally straightens parts using die sets that will be included in your tooling price.

## Concentricity

Two cylindrical surfaces with a common center axis will have a center axis separated by no more than .005" times the difference between the diameters in inches. If the length of the cylinder is greater than two times the diameter, add the straightness tolerance above to concentricity.

Concentricity is not a simple characteristic to measure. Consider changing the control to a runout or position notation.

## Roundness

A roundness profile or "TIR" will fall within the normal linear tolerances. Premium tolerances can easily be achieved on small diameters.

## Angularity/Perpendicularity/Draft

A good production tolerance is +/- 0.5 degree or +/- .008" per inch of length. This figure may vary, depending upon the shape of the piece. Some surfaces will be drafted up to .005" per inch of length, but draft is not normally needed if it will interfere with part function.

### Straightness

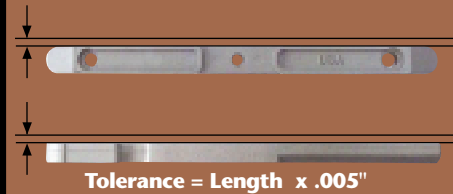

### Concentricity



### Angularity

Tolerance =  $\pm 0.5^\circ$

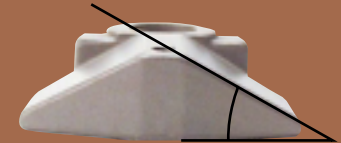

### Perpendicularity

Tolerance =  $\pm 0.008"$  x height

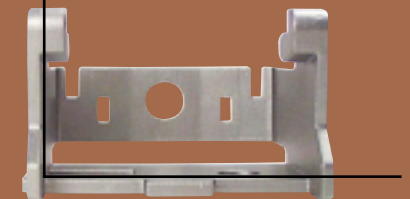

## Surface Texture

Roughness (Ra), as measured by a stylus instrument, will be 125 microinch maximum for parts of small sections that weigh 0.5 pound or less. Larger parts may be rougher than 125 microinch. If this is important for part function, be sure to make these needs known. Secondary finishing operations can be used to improve this surface texture.

## Radii

Normally, large fillet and corner radii reduce stress in the part and improve appearance. Design with the largest fillet radii that are practical. Allow .062" R maximum outside corner radii where practical. Sometimes outside corners must be tooled sharp, but this is avoided whenever possible.

## Gate Witness

Each part is gated into one or more heavy sections. Normally, a .010" to .025" high gate witness left on the part will allow best manufacturing economy. Advise if this is objectionable.

- ! Gates can be removed flush to the adjacent surface or ground to a specific dimension, but this often results in a higher manufacturing cost.
- ! For accuracy, repeatability, and reduced piece cost, Signicast builds a gate grind fixture for all parts. Uncontrolled hand belting is avoided.
- ! When possible, design part so gate can be put on flat surface rather than curved surface.
- ! Gate witness tolerances in order of increasing costs:
  - **Break-off witness** – .060"-.120" max. depending on part size
  - **Plunge Grind** – .010"-.025" maximum witness
  - **Flush Grind** – to minus .010"
  - **Swivel Grind** – .010"-.025" maximum witness
  - **Grind to dimension**

### Gate Witness Examples

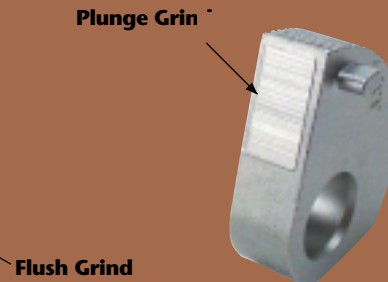
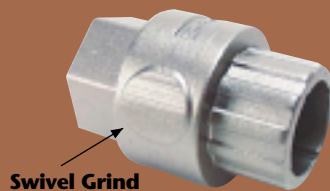

## Holes

Through holes (round or other shape) and slots may be cast to:

SIZE	MAX DEPTH
.040" - .080"	2 x hole diameter
.081" - .200"	3 x hole diameter
.201" - .400"	4 x hole diameter
.401" +	6 x hole diameter

Preformed ceramic coring may allow hole depths up to 30 x diameter, at additional costs.

### Through Holes/Slots

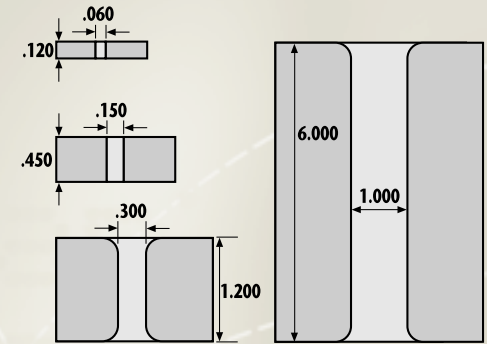

## Blind Holes

In blind hole design, large corner radii blending from the part surface to the hole are necessary to provide adequate core strength. Bottoms of blind holes should be full round or radiused as much as possible.

Blind holes may be cast to:

SIZE	MAX DEPTH	BLENDING CORNER RADII
.040" - .120"	.5 x hole diameter	.5 x hole diameter
.121" - .400"	1 x hole diameter	.060" - .090"
.401" +	2 x hole diameter	.091" - .180"

### Cast Features: Blind Holes

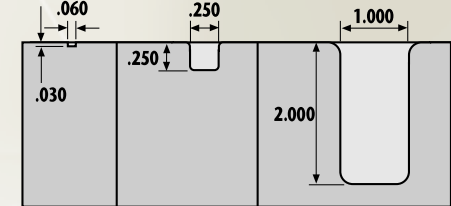

Preformed ceramic cores can be used to allow greater blind hole depths, but add significant cost to the casting.

- ! Incorporate countersinks and counterbores with the cast holes for improved economy.

## Wall Thickness

Minimum wall thickness and corner radii depend upon part configuration and size. Small investment castings may have walls cast to .030" thickness. Medium to large castings require .060"-.100" walls depending on the part geometry.

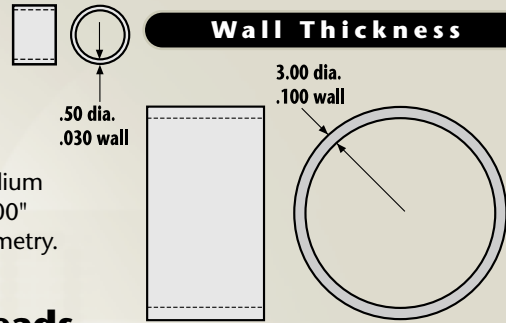

## Splines/Gears/Threads

Gear and thread profiles can be produced with accuracies of +/- .004" per .5" of pitch. Longer lengths or larger diameters can be held to normal or premium linear tolerances as necessary.

## Letters/Numbers/Logos

Normally, raised letters or numbers in protective depressed pads are easiest to manufacture. A .020" high character on a depressed pad yields sharp, castable features. Specify exact text and dimensions of the figures. Logos can be investment cast to almost any design.

## Gaging

Signicast performs a 100% visual inspection of all parts. If dimensional verification is required, a sampling plan and process control is less expensive than 100% gaging of each part.

**Important:** Whenever custom gages are used, there should be identical gages at Signicast and at the customer's facility.

**!** Fixed gages such as go-no-go are less expensive to use than gages with dial indicators.

## External Splines



## Splined Couplers

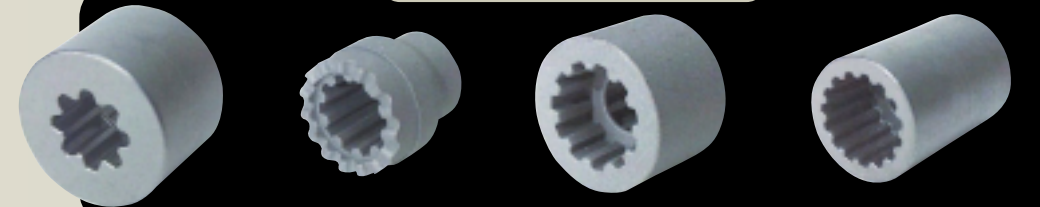

## Spur Gears

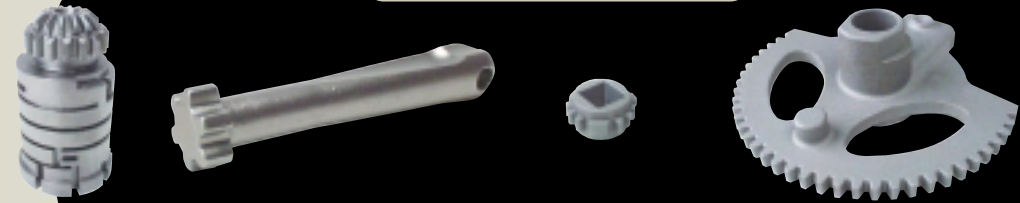

## Cast Threads



## Internal Splines



## Logo and Lettering



### References:

*Investment Casting Handbook, 1997* – Shows many applications, design data, alloy selection information, and quality control information.

*Dimensioning and Tolerancing – ANSI Y 14.5* – An excellent engineering drawing standard published by the American Society of Mechanical Engineers. This standard defines symbols, describes tolerance and datum methods, and contains valuable information to assist design of mating components.